

## Z2 Knife Folding Unit

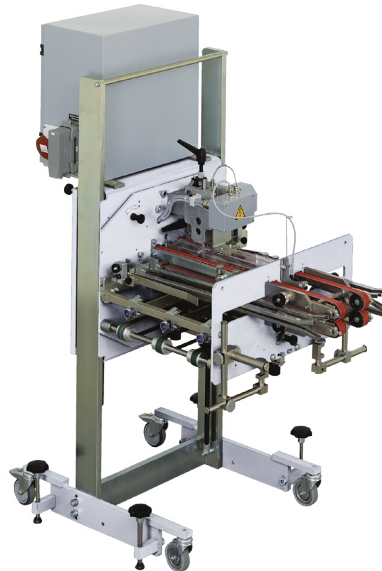

The Z2 is a knife folding unit from MBO that features a pivoting knife section which can be configured to perform an upward or downward fold. After the fold takes place, product can be delivered to either the left or right depending upon the operator's settings. The Z2 also features an independent self control, meaning it can be used in a wider range of configurations including lines with older machines or machines from other suppliers.

## Features & Benefits

- Intuitive control panel for easy setup and operation
- Top and bottom conveyor belt system allows superior product control and folding precision
- Compatible with a wide range of MBO and Herzog+Heymann finishing modules
- Independent self-control allows operators to set this unit to a different speed from the rest of the line, it also allows the operator to integrate this knife folding unit into any system
- 180 degree pivoting knife section allows for top-down or bottom-up knife folding

Machine		Z2-48		Z2-65	
		mm	inch	mm	inch
Infeed Width	Min.	146	5 3/4	146	5 3/4
	Max.	480	18 3/4	650	25 1/2
Infeed Height	Min.	450	17 3/4	450	17 3/4
	Max.	901.7	35 1/2	901.7	35 1/2
		m/min	ft/min	m/min	ft/min
Production Speed	Max.	161.5	530	161.5	530
Knife Speed	Max.	up to 15000 cycles/hour		up to 15000 cycles/hour	

\*Technical specifications subject to change without notice.  
 \*\*Technical specifications vary depending upon paper quality.

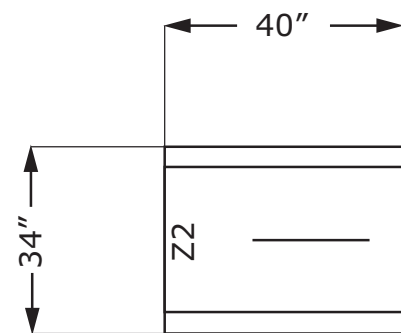

Multiple solutions to help you grow your bottom line.

4 Stow Road Marlton NJ, 08053 (609) 267-2900  
 info@mboamerica.com sales@mboamerica.com