

# KL 112.1

## Miniature Folding Machine



# KL 112.1 – Miniature Folding Machine



The Herzog+Heymann Miniature Folding Machine Series KL112.1 is designed for the production of small and miniature folded products. Due to the fold roller diameter of just 26 mm, a minimal fold length of up to 18 mm can be achieved. In combination with a maximum buckle plate number of up to 16 buckle plates, large sheets can be folded down to a minimal end format.

Flexibility is one of the strengths of the KL112.1 folding machine series: regardless of whether you want to manufacture products for pharmaceuticals (such as inserts and outserts), operating manuals or glued and tacked booklets. The modular design means that the right configuration and solution is available for every requirement and every product. In addition, existing components as well as units from the Herzog+Heymann M7 and M8 series can also be combined.



# Configuration Options



KL 112.1 with flat pile feeder

## Various feeder systems

- Flat pile feeder
- Continuous feeder for continuous production
- Stream suction feeder for feeding miniature formats
- Web finishing using unwinder and sheeter



KL 112.1 with corresponding cross-fold unit and continuous feeder



KL 112.1 with stream suction feeder



Example of web finishing using MBO unwinder

# Options



Camera- and waterscoring system

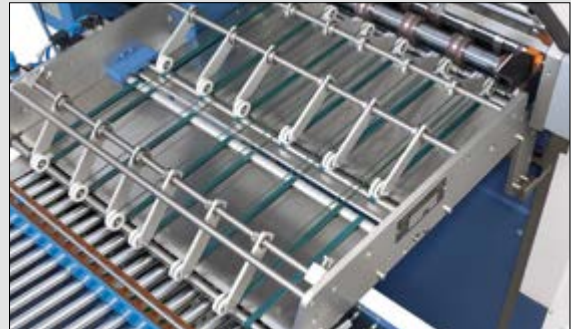

Transfer unit with sheet ejector unit



Tried and tested, low-maintenance gear drive



Pre- and rear slitter shaft for cutting, scoring and perforating

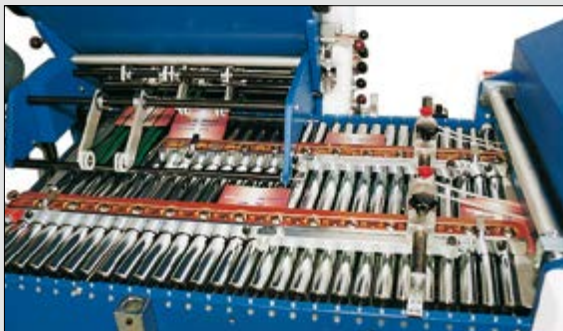

Double stream device



Double gatefold plate



Integrated gluing system for fold gluing



Sheet monitoring system

# Additional units

## Deliveries for the KL 112.1

The selection of delivery systems ranges from simple stream delivery units through to efficient vertical stacker delivery systems for up to 4-up jobs. All Herzog+Heymann

delivery systems are modular and manually or electrically height-adjustable, making them very flexible in use.



Stream delivery



Vertical stacker delivery

## Add-on units

Depending on customer requirements, additional finishing units may be necessary to be able to manufacture specific products. As well as small format and belt presses, parallel and crossfold knife units, cutting and scoring

devices as well as labelers and more can be integrated into the Herzog+Heymann KL 112.1 folding range in a modular way.



Marking device for lateral offset of single and multiple-up sheets



Cutting and scoring unit



Crossfold knife unit

# Options

## Miniature Folding Machine KL112.1

- Stream suction, flat pile or continuous feeders (mobile or fixed)
- Working widths: 35 cm (13 2/3"), 45 cm (17 3/5") and 52 cm (20 2/5")
- 2-16 buckle plates
- Integrated camera system for mix-up control
- Cold gluing system and coordinating segmented fold rollers
- Sheet monitoring system
- Conveyors with spreader and ejector functions
- Crossfold and parallel fold knife units
- Pressing units for even flatter products
- Labelers
- Stream delivery or vertical stacker delivery

# Technical Specifications

Folding unit working width		350 mm (13 2/3")	450 mm (17 3/5")	520 mm (20 2/5")
Stream suction feeder	Min.	50 mm x 40 mm (2" x 1 5/8")	50 mm x 40 mm (2" x 1 5/8")	50 mm x 40 mm (2" x 1 5/8")
	Max.	350 mm x 550 mm (13 2/3" x 21 2/3")	450 mm x 650 mm (17 3/4" x 25 3/5")	520 mm x 650 mm (20 2/5" x 25 3/5")
Flat pile feeder	Min.	–	80 mm x 105 mm (3 1/8" x 4 1/8")	80 mm x 105 mm (3 1/8" x 4 1/8")
	Max.	–	450 mm x 1,000 mm (17 3/4" x 40")	520 mm x 1,000 mm (20 2/5" x 40")
Continuous feeder	Min.	–	–	150 mm x 180 mm (6" x 7")
	Max.	–	–	520 mm x 1,000 mm (20 2/5" x 40")
Folding length min.	18 mm (3/4 inch)			
Number of buckle plates	2 bis 16			
Speed	35 bis 150 m/min			

05/2016\_v1

Floorplan KL 112.1 with flat pile feeder F465 and delivery 177.1

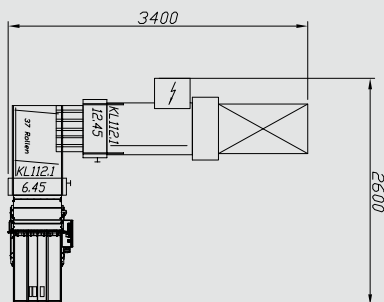

Floorplan KL 112.1 with continuous feeder R535 and delivery 177.1

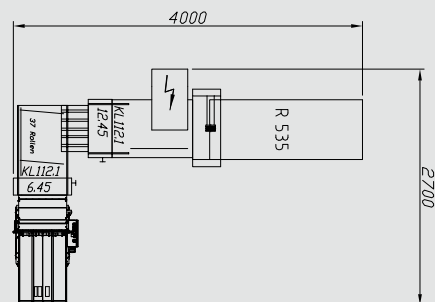

**Herzog+Heymann GmbH & Co. KG**  
 Dunlopstraße 45+47 ■ 33689 Bielefeld ■ Germany  
 Phone +49 (0) 5205/7509-0 ■ info@herzog-heyman.com  
[www.herzog-heyman.com](http://www.herzog-heyman.com)

**HERZOG + HEYMANN**  
 Member of the MBO Group