

■ UW 520 Digital Unwinding Machine



The UW 520 is a digital unwinding machine featuring dancer-controlled web tension and a center driven servo motor. It comes equipped with an electric paper lift, an integrated splice table, as well as a de-curling device making it easy to operate and quick to set-up. This machine is designed to be integrated into any digital printing or web finishing line.

Standard Features

- Web guide control
- Core shaft with pneumatic tensioning
- Electric paper lift
- Variable or constant web tension capable
- Fast web change splice table
- De-curling device
- Robust chain drive

Optional Features

- Various core shaft diameters
- Automatic splice detection

*All features are subject to change without notice.

Multiple solutions to help you grow your bottom line.

4 Stow Road Marlton NJ, 08053 (609) 267-2900
info@mboamerica.com sales@mboamerica.com

UW 520

Technical Specifications			
		mm	inch
Roll Diameter	Max.	1320	52
Web Width	Min.	150	6
	Max.	520	20 1/2
Core diameter		70	3
		m/min	feet/min
Production Speed		300	990
Paper Stock	Min.	40 gr/m ²	
	Max.	250 gr/m ²	
Air Pressure		6 bar 98 PSI	
Power Requirements		3 LNPE, 400VAC, 50-60Hz, 32A	

*Technical specifications are subject to change without notice.
 **Technical specifications may vary depending upon paper quality.

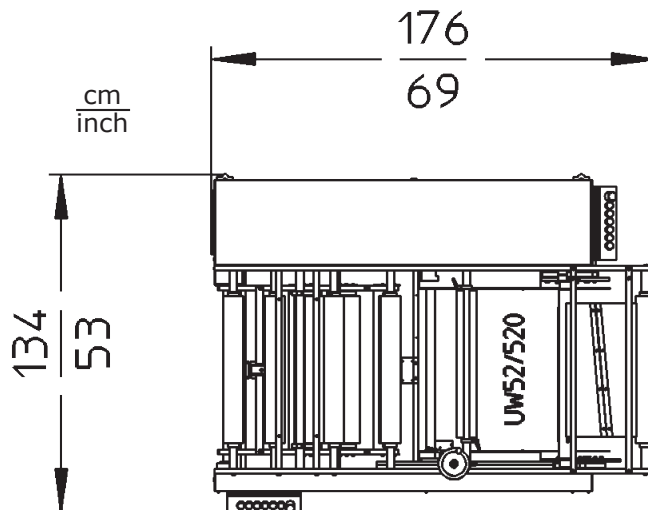

Multiple solutions to help you grow your bottom line.

4 Stow Road Marlton NJ, 08053 (609) 267-2900
 info@mboamerica.com sales@mboamerica.com