

## FC 23/30 Aqueous and UV Coating Unit for Webs

The FC web coating unit, available in 23" and 30" wide web widths, applies aqueous (water based) or UV based (chemical based) protective and tactile coatings to a printed web at full press or finishing web speed. Based solidly on a flexo application design, the FC is a completely self contained unit, servo driven, with interface capability to any printing press or finishing line. It is most commonly used for gloss or matte finish coatings to protect and enhance the printed web. Protection and enhancement are key factors in the production of direct mail products and marketing products, ultimately turning into higher conversion rates. The FC can be configured as and aqueous unit only, a UV unit only, or a combination unit to universally fit any application.



### Why Coating?

- Print coatings can help your printed products stand out by making them more durable, more elegant or by bringing the reader's attention to the product
- Coatings can provide tactile effects that make the printed product look and feel unique
- Coatings provide durability to increase shelf life and weather the rigors of mail processing
- Many Coatings are green processes vs. Lamination

### Common Uses

- Postcards, Brochures
- Direct Mail, Flyers
- Books, Covers
- Protect, Enhance, Embellish
- Gloss, Matte, Satin, Silk, Soft-Touch
- Scented, Glitter, Textured
- Lamination simulation



Multiple solutions to help you grow your bottom line.

4 East Stow Road, Suite 12, Marlton NJ, 08053 (609) 267-2900

Web: [www.mboamerica.com](http://www.mboamerica.com) Parts: [Store.mboamerica.com](http://Store.mboamerica.com) Email: [Info@mboamerica.com](mailto:Info@mboamerica.com)

**Technical Data**

**Quick Change Anilox and Transfer Sleeve**

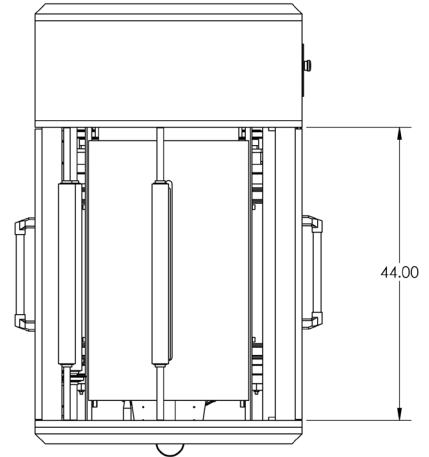

**UV and/or IR Integrated Dryer**



DRYER UV MODULE

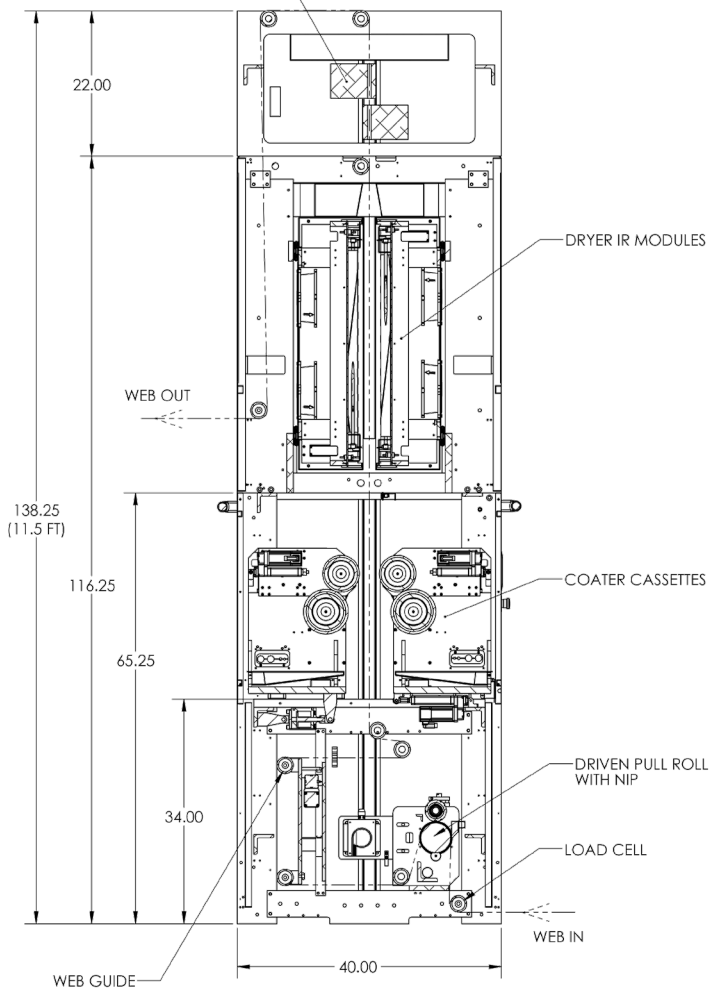

23" Unit Shown

**Enclosed, High Flow Rate Chamber**



Multiple solutions to help you grow your bottom line.

4 East Stow Road, Suite 12, Marlton NJ, 08053 (609) 267-2900

Web: [www.mboamerica.com](http://www.mboamerica.com) Parts: [Store.mboamerica.com](http://Store.mboamerica.com) Email: [Info@mboamerica.com](mailto:Info@mboamerica.com)